

HR COMBO

Hammond **ROTO FINISH**

VIBRATORY FINISHING MACHINES



HRC-11

The **HR Combo Series** features the same structural design as the HR Series machines, but also adds a second chamber for parts drying. This structure utilizes the same tank head design for structural integrity. The addition of the second chamber to the outside of the process area reduces costs and floor space. With unload gates available for both the processing and drying channel, this is one of our most versatile machines.

- **One Drive System**
- **One Machine that Processes & Dries Parts**
- **One Electrical Panel**
- **Smaller Footprint**

FEATURES

- **Heavy duty Welded Steel Construction**
Main building component of the bowl is 1/2" thick pressure vessel material.
- **Cast Polyurethane Liner**
Polyurethane liner is cast, not sprayed on. This improves media rebound and provides more wear depth. 50% additional lining in high wear areas.
- **"U" Shaped Straight or Curved Wall Processing Bowl**
- **Full 90° Wrap-Around Separation Screen**
- **Cartridge Drive System**
Features adjustable top and bottom eccentric weights. Drive exchange program with in-stock availability.
- **Premium Efficiency, T-frame Motor 230 or 460/3/60**
Specify 230 or 460 volts. Motor is mounted to non-vibrating base. Belt drive to main shaft for 1,250 V.P.M.
- **Water-Driven Compound System**
- **Heat Lamp(s), with Control Panel Mounted Controls**



HR COMBO SERIES

Specifications

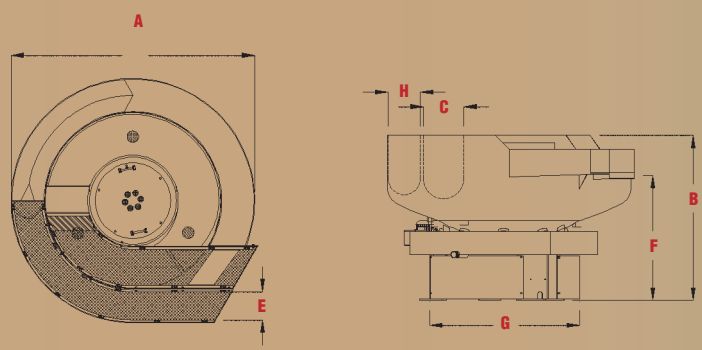

MODEL	Total Capacity L (cu.ft.)	Max Working Capacity L (cu.ft.)	Dryer Channel Capacity L (cu.ft.)	A Overall Diameter mm (in.)	B Overall Height mm (in.)	C Process Channel Width mm (in.)	E Screen Deck Width mm (in.)	F Screen Deck Height mm (in.)	G Base Diameter mm (in.)	H Dryer Channel Width mm (in.)	Drain Sizes mm (in.) / # of Drains	Motor Horse Power kw (HP)	460 Volts Amp Load	230 Volts Amp Load	Aprox Shipping Weight kg (lbs.)
HRC-3 SL CL	165 (5.5)	75 (2.5)	48 (1.7)	1321 (52)	1155 (45.5)	190 (7.5)	152 (6)	939 (37)	1041 (41)	119 (4.68)	101.6 (4) / 1	2.2 (3)	7.8	12.6	997.9 (2,200)
HRC-5 SL CL	300 (10.71)	150 (5)	68 (2.4)	1676 (66)	1181 (46.5)	259 (10.2)	203 (8)	873 (39)	1193 (47)	214 (8.43)	101.6 (4) / 3	2.2 (3)	7.8	12.6	1360.8 (3,000)
HRC-11 SL CL	601 (20.4)	300 (10.6)	283 (10)	2134 (84)	1320 (52)	317 (12.5)	279 (11)	1066 (42)	1448 (57)	249 (9.8)	101.6 (4) / 3	5.6 (7.5)	14	25	2267.9 (5,000)
HRC-17 SPT	990 (33.1)	381 (15)	566 (20)	2438 (96)	1346 (53)	381 (15)	330 (13)	1016 (40)	1702 (67)	330 (13)	101.6 (4) / 3	7.5 (10)	17	31	2494.7 (5,500)
HRC-17 CPT	990 (33.1)	340 (12)	566 (20)	2438 (96)	1346 (53)	381 (15)	330 (13)	1016 (40)	1702 (67)	330 (13)	101.6 (4) / 3	7.5 (10)	17	31	2492.7 (5,500)
HRC-23 SPT CPT	1500 (50.3)	540 (19)	512 (18.1)	2540 (100)	1346 (53)	457 (18)	381 (15)	1066 (42)	1702 (67)	305 (12)	101.6 (4) / 3	7.5 (10)	17	31	2812.2 (6,200)
HRC-29 SPT CPT	1699 (60.0)	780 L (26)	994 (35.1)	2845 (112)	1372 (54)	508 (20)	432 (20)	1118 (44)	1702 (67)	405 (16)	101.6 (4) / 3	11.1 (15)	17	31	2993.7 (6,600)

HRC-11
Shown with optional
Dust Cover



Abbreviation Key

- SL** - Straight Wall, Lever
- CL** - Curved Wall, Lever
- SPT** - Straight Wall, Pneumatic Gate, Timer
- CPT** - Curved Wall, Pneumatic Gate, Timer

HRC-3, 5

- Semi-Automatic Control Panel
- Digital Process Timer
- Water Driven Compound System
- Manual Lever Gate
- Grease Drive System
- 1 Heat Lamp Assembly
- Internal Stainless Wrap Screen

HRC-11, 17, 23, 29

- Semi-Automatic Control Panel
- Digital Process Timer
- Water Driven Compound System
- Pneumatic Gate
- Recirculating Oil Lube Drive System
- 2 Heat Lamp Assemblies - HRC-11, HRC-17
- 3 Heat Lamp Assemblies - HRC-23, HRC-29
- Internal Stainless Wrap Screen

